

LEGEND

The Ultimate in Style & Performance[®]



Legend 3-Wheel Scooter



Legend 4-Wheel Scooter

OWNER'S MANUAL

SAFETY GUIDELINES



WARNING! An authorized Pride Provider or qualified technician must perform the initial setup of this scooter and must perform all of the procedures in this manual.

The symbols below are used throughout this owner's manual and on the scooter to identify warnings and important information. It is very important for you to read them and understand them completely.



WARNING! Indicates a potentially hazardous condition/situation. Failure to follow designated procedures can cause either personal injury, component damage, or malfunction. On the product, this icon is represented as a black symbol on a yellow triangle with a black border.



MANDATORY! These actions should be performed as specified. Failure to perform mandatory actions can cause personal injury and/or equipment damage. On the product, this icon is represented as a white symbol on a blue dot with a white border.



PROHIBITED! These actions are prohibited. These actions should not be performed at any time or in any circumstances. Performing a prohibited action can cause personal injury and/or equipment damage. On the product, this icon is represented as a black symbol with a red circle and red slash.

Please fill out the following information for quick reference:

Pride Provider: _____	
Address: _____	
Phone Number: _____	
Purchase Date: _____	Serial Number: _____

NOTE: This owner's manual is compiled from the latest specifications and product information available at the time of publication. We reserve the right to make changes as they become necessary. Any changes to our products may cause slight variations between the illustrations and explanations in this manual and the product you have purchased. The latest/current version of this manual is available on our website.



Copyright © 2007
Pride Mobility Products Corp.

INFMANU2020/Rev F/May 2007

CONTENTS

I. INTRODUCTION.....	4
II. SAFETY	6
III. EMI/RFI	18
IV. SPECIFICATIONS	19
V. YOUR SCOOTER	21
VI. BATTERIES AND CHARGING	25
VII. OPERATION	30
VIII. COMFORT ADJUSTMENTS.....	32
IX. DISASSEMBLY AND ASSEMBLY	35
X. BASIC TROUBLESHOOTING	38
XI. CARE AND MAINTENANCE	40
XII. WARRANTY	43

I. INTRODUCTION

SAFETY

WELCOME to Pride Mobility Products Corporation (Pride). The product you have purchased combines state-of-the-art components with **safety**, comfort, and styling in mind. We are confident that these design features will provide you with the conveniences you expect during your daily activities. Understanding how to **safely** operate and care for this product should bring you years of trouble free operations and service.

Read and follow all instructions, warnings, and notes in this manual and all other accompanying literature before attempting to operate this product for the first time. In addition, your **safety** depends upon you, as well as your provider, caretaker, or healthcare professional in using good judgement.

If there is any information in this manual which you do not understand, or if you require additional assistance for setup or operation, please contact your authorized Pride Provider. **Failure to follow the instructions, warnings, and notes in this manual and those located on your Pride product can result in personal injury or product damage and will void Pride's product warranty.**

PURCHASER'S AGREEMENT

By accepting delivery of this product, you promise that you will not change, alter, or modify this product or remove or render inoperable or unsafe any guards, shields, or other safety features of this product; fail, refuse, or neglect to install any retrofit kits from time to time provided by Pride to enhance or preserve the safe use of this product.

SHIPPING AND DELIVERY

Before using your scooter, make sure your delivery is complete as some components may be individually packaged. If you do not receive a complete delivery, please contact your authorized Pride Provider immediately. Where damage has occurred during transport, either to the packaging or content, please contact the delivery company responsible.

INFORMATION EXCHANGE

We want to hear your questions, comments, and suggestions about this manual. We would also like to hear about the safety and reliability of your new scooter, and about the service you received from your authorized Pride Provider. Please notify us of any change of address, so we can keep you apprised of important information about safety, new products, and new options that can increase your ability to use and enjoy your scooter. Please feel free to contact us at the address below:

USA:
Pride Mobility Products Corporation
Attn: Customer Care Department
182 Susquehanna Ave.
Exeter, PA 18643-2694

Canada:
Pride Mobility Products Company
380 Vansickle Road Unit 350
St. Catharines, Ontario L2R 6PZ

1-888-570-1113

Customercare@pridemobility.com
1-800-424-8250

NOTE: If you ever lose or misplace your product registration card or your copy of this manual, contact us and we will be glad to send you a new one immediately.

I. INTRODUCTION

PRIDE OWNERS CLUB

As an owner of a Pride product, you are encouraged to enroll in the Pride Owners Club. Complete and return your enclosed product registration card or visit Pride's web site at www.pridemobility.com.

From our home page, select "Owners Club" to enter a page dedicated to current and potential Pride product owners. You will gain access to interviews, stories, recreation ideas, daily living tips, product and funding information, and interactive message boards. These message boards invite you to communicate with other Pride customers as well as Pride representatives who are available to assist you with any questions or concerns.

II. SAFETY

PRODUCT SAFETY SYMBOLS

The symbols below are used on the scooter to identify warnings, mandatory actions, and prohibited actions. It is very important for you to read and understand them completely.



Read and follow the information in the owner's manual.



Do not allow unsupervised children to play near the scooter while the batteries are charging.



Maximum seating weight.



Pinch/Crush points created during assembly.



Corrosive chemicals contained in battery. Use only AGM or Gel-Cell batteries to reduce the risk of leakage or explosive conditions.



EMI-RFI- This product has been tested and passed at an immunity level of 20 V/m.

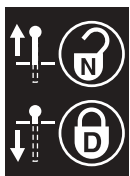

Unlocked and in freewheel mode.

Locked and in drive mode.

II. SAFETY



Use only AGM or Gel-Cell batteries.



Front-to-rear plug orientation.



Do not raise or lower the power seat while the scooter is in motion.



Do not remove anti-tip wheels.



Do not use a cell phone, walkie/talkie, laptop, or other radio transmitter while operating.



Avoid exposure to rain, snow, ice, salt, or standing water whenever possible. Maintain and store in a clean and dry condition.



Removal of grounding prong can create electrical hazard. If necessary, properly install an approved 3-pronged adapter to an electrical outlet having 2-pronged plug access.



Do not connect an extension cord to the AC/DC converter or the battery charger.



Contact with tools can cause electrical shock.

II. SAFETY



Do not use batteries with different amp-hour (Ah) capacities. Do not mix old and new batteries. Always replace both batteries at the same time.



Do not lift the mobility product while seated in it.



Explosive conditions exist!



Keep your hands away from the tires when driving. Be aware that loose fitting clothing can become caught in the drive tires.



Disposal and recycling-Contact your authorized Pride Provider for information on proper disposal of your Pride product and its packaging.



Disposal and recycling-Contact your authorized Pride Provider for information on proper disposal of your Pride product and its packaging.



Wear safety goggles.



Contains lead.



Battery charger for indoor use only.

II. SAFETY

GENERAL



MANDATORY! Do not operate your new scooter for the first time without completely reading and understanding this owner's manual.

Your scooter is a state-of-the-art life-enhancement device designed to increase mobility. Pride provides an extensive variety of products to best fit the individual needs of the scooter user. Please be aware that the final selection and purchasing decision regarding the type of scooter to be used is the responsibility of the scooter user who is capable of making such a decision and his/her healthcare professional (i.e., medical doctor, physical therapist, etc.).

The contents of this manual are based on the expectation that a mobility device expert has properly fitted the scooter to the user and has assisted the prescribing healthcare professional and/or the authorized Pride Provider in the instruction process for the use of the product.

There are certain situations, including some medical conditions, where the scooter user will need to practice operating the scooter in the presence of a trained attendant. A trained attendant can be defined as a family member or care professional specially trained in assisting a scooter user in various daily living activities.

As you begin using your scooter during daily activities, you will probably encounter situations in which you will need some practice. Simply take your time and you will soon be in full and confident control as you maneuver through doorways, on and off elevators, up and down ramps, and over moderate terrain.

Below are some precautions, tips, and other safety considerations that will help you become accustomed to operating the scooter safely.

MODIFICATIONS

Pride has designed and engineered your scooter to provide maximum mobility and utility. However, under no circumstances should you modify, add, remove, or disable any feature, part, or function of your scooter.



WARNING! Do not modify your scooter in any way not authorized by Pride. Do not use accessories if they have not been tested or approved for Pride products.

REMOVABLE PARTS



WARNING! Do not attempt to lift or move your scooter by any of its removable parts, including the armrests, seat, or shroud.

PRE-RIDE SAFETY CHECK

Get to know the feel of your scooter and its capabilities. Pride recommends that you perform a safety check before each use to make sure your scooter operates smoothly and safely.

II. SAFETY

Perform the following inspections prior to using your scooter:

- Check for proper tire inflation (if equipped with pneumatic tires).
- Check all electrical connections. Make sure they are tight and not corroded.
- Check all harness connections. Make sure they are secured properly.
- Check the brakes.
- Check battery charge.

If you discover a problem, contact your authorized Pride Provider for assistance.

TIRE INFLATION

If your scooter is equipped with pneumatic tires, you should check or have the air pressure checked at least once a week. Proper inflation pressures will prolong the life of your tires and help ensure the smooth operation of your scooter.

WARNING! It is critically important that 30-35 psi tire pressure be maintained in pneumatic tires at all times. Do not underinflate or overinflate your tires. Low pressure may result in loss of control, and overinflated tires may burst. Failure to maintain 30-35 psi tire pressure in pneumatic tires at all times may result in tire and/or wheel failure.



WARNING! Inflate your scooter tires from a regulated air source with an available pressure gauge. Inflating your tires from an unregulated air source could overinflate them, resulting in a burst tire.

WARNING! When changing a tire, remove only the center lug nut, then remove the wheel. If any further disassembly is required, deflate the tire completely or it may explode.

WEIGHT LIMITATIONS

Your scooter is rated for a maximum weight capacity. Refer to the specifications table for information.



MANDATORY! Stay within the specified weight capacity of your scooter. Exceeding the weight capacity voids the warranty. Pride will not be held responsible for injuries and/or property damage resulting from failure to observe weight limitations.



WARNING! Do not carry passengers on your scooter. Carrying passengers on your scooter may affect the center of gravity, resulting in a tip or a fall.

INCLINE INFORMATION

More and more buildings have ramps with specified degrees of inclination, designed for easy and safe access. Some ramps may have turning switchbacks (180-degree turns) that require you to have good cornering skills on your scooter.

- Proceed with extreme caution as you approach the downgrade of a ramp or other incline.
- Take wide swings with your scooter around any tight corners. If you do that, the scooter's rear wheels will follow a wide arc, not cut the corner short, and not bump into or get hung up on any railing corners.
- When driving down a ramp, keep the scooter's speed adjustment set to the slowest speed setting to ensure a safely controlled descent.
- Avoid sudden stops and starts.

II. SAFETY

When climbing an incline, try to keep your scooter moving. If you must stop, start up again slowly, and then accelerate cautiously. When driving down an incline, do so by setting the speed adjustment dial to the slowest setting and driving in the forward direction only. If your scooter starts to move down the incline faster than you anticipated or desired, allow it to come to a complete stop by releasing the throttle control lever. Then push the throttle control lever forward slightly to ensure a safely controlled descent.

WARNING! When climbing an incline, do not zigzag or drive at an angle up the face of the incline. Drive your scooter straight up the incline. This greatly reduces the possibility of a tip or a fall. Always exercise extreme caution when negotiating an incline.

WARNING! Do not drive your scooter across the side of an incline or diagonally up or down an incline; do not stop, if possible, while driving up or down an incline.



WARNING! You should not travel up or down a potentially hazardous incline (i.e., areas covered with snow, ice, cut grass, or wet leaves).

WARNING! When on any sort of an incline or decline, never place the scooter in freewheel mode while seated on it or standing next to it.

WARNING! Even though your scooter is capable of climbing slopes greater than those illustrated in figures 1 and 1A, do not, under any circumstances, exceed the incline guidelines or any other specifications presented in this manual. Doing so could cause instability in your scooter.

Handicap public access ramps are not subject to government regulation in all countries, and therefore do not necessarily share the same standard percent of slope. Other inclines may be natural or, if man-made, not designed specifically for scooters. Figures 1 and 1A illustrate your scooter's stability and its ability to climb grades under various weight loads and under controlled testing conditions.

These tests were conducted with the scooter's seat in the highest position and adjusted rearward on the seat base to its farthest rearward position. Use this information as a guideline. Your scooter's ability to travel up inclines is affected by your weight, your scooter's speed, your angle of approach to the incline, and your scooter setup.

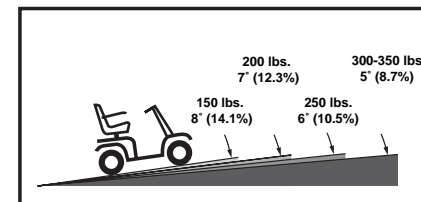

Figure 1. (3-wheel) Maximum Recommended Incline Angles

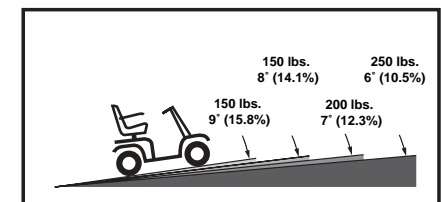

Figure 1A. (4-wheel) Maximum Recommended Incline Angles



WARNING! Any attempt to climb or descend a slope steeper than what is shown in figures 1 and 1A may put your scooter in an unstable position and cause it to tip.

WARNING! Never carry an oxygen tank weighing more than 15 lbs. Never fill the front or rear basket with contents exceeding 15 lbs.

II. SAFETY

When you approach an incline, it is best to lean forward. See figures 2 and 2A. This shifts the center of gravity of you and your scooter toward the front of the scooter for improved stability.

NOTE: When negotiating ramps, if the throttle control lever is released while moving forward, the powered scooter may "rollback" approximately 1 foot before the brake engages. If the throttle control lever is released while moving in reverse, the powered scooter may "rollback" approximately 3 feet before the brake engages.

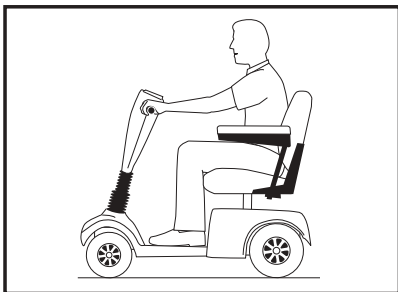

Figure 2. Normal Driving Position

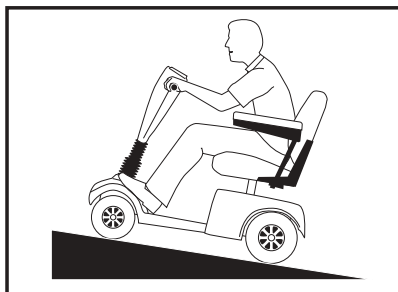

Figure 2A. Increased Stability Driving Position

CORNERING INFORMATION

Excessively high cornering speeds can create the possibility of tipping. Factors which affect the possibility of tipping include, but are not limited to, cornering speed, steering angle (how sharply you are turning), uneven road surfaces, inclined road surfaces, riding from an area of low traction to an area of high traction (such as passing from a grassy area to a paved area – especially at high speed while turning), and abrupt directional changes. High cornering speeds are not recommended. If you feel that you may tip over in a corner, reduce your speed and steering angle (i.e., lessen the sharpness of the turn) to prevent your scooter from tipping.



WARNING! When cornering sharply, reduce your speed and maintain a stable center of gravity. When using your scooter at higher speeds, do not corner sharply. This greatly reduces the possibility of a tip or fall. Always exercise common sense when cornering.

BRAKING INFORMATION

Your scooter is equipped with these powerful brake systems:

- Regenerative: Uses electricity to rapidly slow the vehicle when the throttle control lever returns to the centre/stop position.
- Disc Park Brake: Activates mechanically after regenerative braking slows the vehicle to near stop, or when power is removed from the system for any reason.

II. SAFETY

OUTDOOR DRIVING SURFACES

Your scooter is designed to provide optimum stability under normal driving conditions—dry, level surfaces composed of concrete, blacktop, or asphalt. However, Pride recognizes that there will be times when you will encounter other surface types. For this reason, your scooter is designed to perform admirably on packed soil, grass, and gravel. Feel free to use your scooter safely on lawns and in park areas.

- Reduce your scooter's speed when driving on uneven terrain and/or soft surfaces.
- Avoid tall grass that can become tangled in the running gear.
- Avoid loosely packed gravel and sand.
- If you feel unsure about a driving surface, avoid that surface.

PUBLIC STREETS AND ROADWAYS



WARNING! You should not operate your scooter on public streets and roadways. Be aware that it may be difficult for traffic to see you when you are seated on your scooter. Obey all local pedestrian traffic rules. Wait until your path is clear of traffic, and then proceed with extreme caution.

STATIONARY OBSTACLES (STEPS, CURBS, ETC.)

WARNING! Do not drive near raised surfaces, unprotected ledges and/or drop-offs (curbs, porches, stairs, etc.).

WARNING! Do not attempt to have your scooter climb or descend an obstacle that is inordinately high.



WARNING! Do not attempt to have your scooter proceed backward down any step, curb, or other obstacle. This may cause the scooter to tip.

WARNING! Be sure your scooter is traveling perpendicular to any curb you may be required to ascend or descend. See figures 3 and 3A.

WARNING! Do not attempt to negotiate a curb that has a height greater than 2 in.

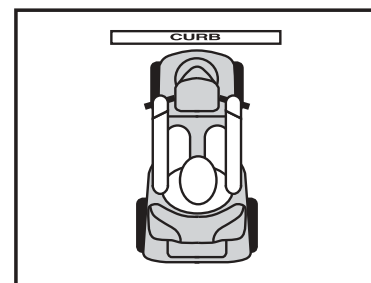

Figure 3. Correct Curb Approach

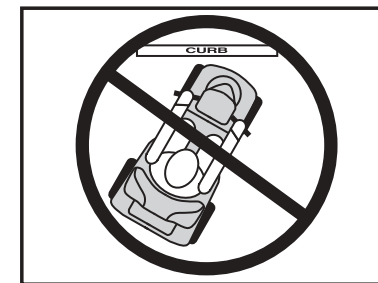

Figure 3A. Incorrect Curb Approach

II. SAFETY

INCLEMENT WEATHER PRECAUTIONS

Exposure of your scooter to inclement weather conditions should be avoided whenever possible. If suddenly caught up in rain, snow, severe cold or heat while operating your scooter, proceed to shelter at the earliest opportunity. Thoroughly dry your scooter before storing, charging, or operating your scooter.



PROHIBITED! Operating in rain, snow, salt, mist/spray conditions and on icy/slippery surfaces may have an adverse affect on the electrical system. Maintain and store your scooter in a dry and clean condition.



WARNING! Prolonged exposure to hot or cold conditions may affect the temperature of upholstered and non-upholstered items on the scooter, possibly resulting in skin irritation. Exercise caution when using your scooter in extremely hot or cold conditions or when exposing your scooter to direct sunlight for prolonged periods of time.

FREEWHEEL MODE

Your scooter is equipped with a manual freewheel lever that, **when pulled up**, allows the scooter to be pushed. For more information about how to place your scooter into and out of freewheel mode, see V. “Your Scooter.”



WARNING! When your scooter is in freewheel mode, the braking system is disengaged.

- Disengage the drive motors only on a level surface.
- Ensure the key is removed from the key switch.
- Stand beside the scooter to engage or disengage freewheel mode. Never sit on a scooter to do this.
- After you have finished pushing your scooter, always return it to the drive mode to lock the brakes.

An added feature built into the scooter is “**push-too-fast**” protection which safeguards the scooter against gaining excessive speed while in freewheel mode.

“Push-too-fast” operates differently depending on which of two conditions exists:

- If the key is switched “off” while in freewheel mode, the scooter’s controller activates regenerative braking when the scooter is pushed faster than a maximum threshold which has been preprogrammed. In this case, the controller is acting as a speed governor.
- If the key is switched “on” while in freewheel mode, you will encounter considerable resistance at any speed. This prevents the scooter from gaining unwanted momentum should the manual freewheel lever inadvertently be released while driving the scooter.

STAIRS AND ESCALATORS

Scooters are not designed to travel up or down stairs or escalators. Always use an elevator.



WARNING! Do not use your scooter to negotiate steps or escalators.

DOORS

- Determine if the door opens toward or away from you.
- Use your hand to turn the knob or push the handle or push-bar.
- Drive your scooter gently and slowly forward to push the door open. Or drive your scooter gently and slowly backwards to pull the door open.

II. SAFETY

ELEVATORS

Modern elevators have a door edge safety mechanism that, when pushed, reopens the door(s).

- If you are in the doorway of an elevator when the door(s) begin to close, push on the rubber door edge or allow the rubber door edge to contact the scooter and the door will reopen.
- Use care that pocketbooks, packages, or scooter accessories do not become caught in elevator doors.

NOTE: If your scooter’s turning radius is greater than 60 in., it may be difficult to maneuver in elevators and building entrances. Use caution when attempting to turn or maneuver your scooter in small spaces, and avoid areas that might pose a problem.

LIFT/ELEVATION PRODUCTS

If you will be traveling with your scooter, you may find it necessary to use a lift/elevation product to aid in transportation. Pride recommends that you closely review the instructions, specifications, and safety information set forth by the manufacturer of the lift/elevation product before using that product.



WARNING! Never sit on your scooter when it is being used in connection with any type of lift/elevation product. Your scooter was not designed with such use in mind and any damage or injury incurred from such use is not the responsibility of Pride.

BATTERIES

In addition to following the warnings below, be sure to comply with all other battery handling information.



MANDATORY! Battery posts, terminals, and related accessories contain lead and lead compounds. Wear goggles and gloves when handling batteries and wash hands after handling.

WARNING! Scooter batteries are heavy. See specifications table. If you are unable to lift that much weight, be sure to get help. Use proper lifting techniques and avoid lifting beyond your capacity.



WARNING! Always protect the batteries from freezing and never charge a frozen battery.

WARNING! Connect the battery harnesses in the proper manner. RED (+) cables must be connected to positive (+) battery terminals/posts. BLACK (-) cables must be connected to negative (-) battery terminals/posts. REPLACE cables immediately if damaged. Protective caps must be installed over all battery terminals.

NOTE: If you encounter a damaged or cracked battery, immediately enclose it in a plastic bag and call your authorized Pride Provider for instructions on disposal. Your authorized Pride Provider will also have the necessary information on battery recycling, which is our recommended course of action.

II. SAFETY

MOTOR VEHICLE TRANSPORT

Pride recommends that you do not remain seated in your scooter while traveling in a motor vehicle. The scooter should be stowed in the trunk of a car or in the back of a truck or van with the batteries removed and properly secured.

WARNING! Although your scooter may be equipped with a positioning belt, this belt is not designed to provide restraint during motor vehicle transport. Anyone travelling in a motor vehicle should be properly secured in the motor vehicle seat with safety belts fastened securely.



WARNING! Do not sit on your scooter while it is in a moving vehicle.

WARNING! Always be sure your scooter and its batteries are properly secured when it is being transported. Batteries should be secured in an upright position, and protective caps should be installed on the battery terminals. Batteries should not be transported with any flammable or combustible items.

POSITIONING BELTS

Although your scooter may be equipped with a positioning belt, this belt is not designed to provide proper restraint during motor vehicle transport. Anyone traveling in a motor vehicle should be properly secured in the motor vehicle seat with safety belts fastened securely.

WARNING! Do not sit on your scooter while it is in a moving vehicle.



WARNING! Ensure your scooter and its batteries are properly secured when being transported.

PREVENTING UNINTENDED MOVEMENT



WARNING! If you anticipate being seated in a stationary position for an extended period of time, turn off the power. This will prevent unexpected motion from inadvertent throttle control lever contact.

GETTING ONTO AND OFF OF YOUR SCOOTER

Getting onto and off of your scooter requires a good sense of balance. Please observe the following safety tips when getting onto and off of your scooter:

- Remove the key from the key switch.
- Ensure that your scooter is not in freewheel mode. See V. "Your Scooter."
- Ensure that the seat is secured into place.
- Pivot the armrests up to make getting onto and off of the scooter easier.

WARNING! Position yourself as far back as possible in the scooter seat to prevent the scooter from tipping.



WARNING! Avoid putting all of your weight on the scooter armrests and do not use the armrests for weight bearing purposes, such as transfers. Such use may cause the scooter to tip, resulting in a fall from the scooter.

WARNING! Avoid putting all of your weight on the floorboard. Such use may cause the scooter to tip.

II. SAFETY

REACHING AND BENDING

Avoid reaching or bending while driving your scooter. Bending forward creates the risk of accidental throttle control lever contact. Bending to the side while seated creates the risk of tipping. It is important to maintain a stable center of gravity and keep the scooter from tipping. Pride recommends that the scooter user determine his/her personal limitations and practice bending and reaching in the presence of a qualified attendant.



WARNING! Do not bend, lean, or reach for objects if you have to pick them up from the scooter deck or from either side of the scooter. Movements such as these may change your center of gravity and the weight distribution of the scooter and cause your scooter to tip.



PROHIBITED! Keep your hands away from the tires when driving. Be aware that loose fitting clothing can become caught in drive tires.

POSITIONING BELTS

Your authorized Pride Provider, therapist(s), and other healthcare professionals are responsible for determining your requirement for a positioning belt in order to operate your scooter safely.



WARNING! If you require a positioning belt to safely operate your scooter, make sure it is fastened securely. Serious personal injury may result if you fall from the scooter.

PRESCRIPTION DRUGS/PHYSICAL LIMITATIONS

The scooter user must exercise care and common sense when operating his/her scooter. This includes awareness of safety issues when taking prescribed or over-the-counter drugs or when the user has specific physical limitations.



WARNING! Consult your physician if you are taking prescribed or over-the-counter medication or if you have certain physical limitations. Some medications and limitations may impair your ability to operate your scooter in a safe manner.

ALCOHOL/SMOKING

The scooter user must exercise care and common sense when operating his/her scooter. This includes awareness of safety issues while under the influence of alcohol, or while smoking.

WARNING! Do not operate your scooter while you are under the influence of alcohol, as this may impair your ability to operate the scooter in a safe manner.



WARNING! Pride strongly recommends that you do not smoke cigarettes while seated on your scooter, although the scooter seat has passed the necessary testing requirements for cigarette smoking. You must adhere to the following safety guidelines if you decide to smoke cigarettes while seated on your scooter.

- Do not leave lit cigarettes unattended.
- Keep ashtrays a safe distance from the seat cushions.
- Always make sure cigarettes are completely extinguished before disposal.

III. EMI/RFI

ELECTROMAGNETIC AND RADIO FREQUENCY INTERFERENCE (EMI/RFI)



WARNING! Laboratory tests have shown that electromagnetic and radio frequency waves can have an adverse affect on the performance of electrically-powered mobility vehicles.

Electromagnetic and Radio Frequency Interference can come from sources such as cellular phones, mobile two-way radios (such as walkie-talkies), radio stations, TV stations, amateur radio (HAM) transmitters, wireless computer links, microwave signals, paging transmitters and medium-range mobile transceivers used by emergency vehicles. In some cases, these waves can cause unintended movement or damage to the control system. Every electrically-powered mobility vehicle has an immunity (or resistance) to EMI. The higher the immunity level, the greater the protection against EMI. This product has been tested and has passed at an immunity level of 20 V/M.



WARNING! Be aware that cell phones, two-way radios, laptops, and other types of radio transmitters may cause unintended movement of your electrically-powered mobility vehicle due to EMI. Exercise caution when using any of these items while operating your mobility vehicle and avoid coming into close proximity of radio and TV stations.



WARNING! The addition of accessories or components to the electrically-powered mobility vehicle can increase the susceptibility of the vehicle to EMI. Do not modify your scooter in any way not authorized by Pride.

WARNING! The electrically-powered mobility vehicle itself can disturb the performance of other electrical devices located nearby, such as alarm systems.

NOTE: For further information on EMI/RFI, go to the Resource Center on www.pridemobility.com. If unintended motion or brake release occurs, turn the scooter off as soon as it is safe to do so. Call Pride at 800-424-8205 to report the incident.

IV. SPECIFICATIONS

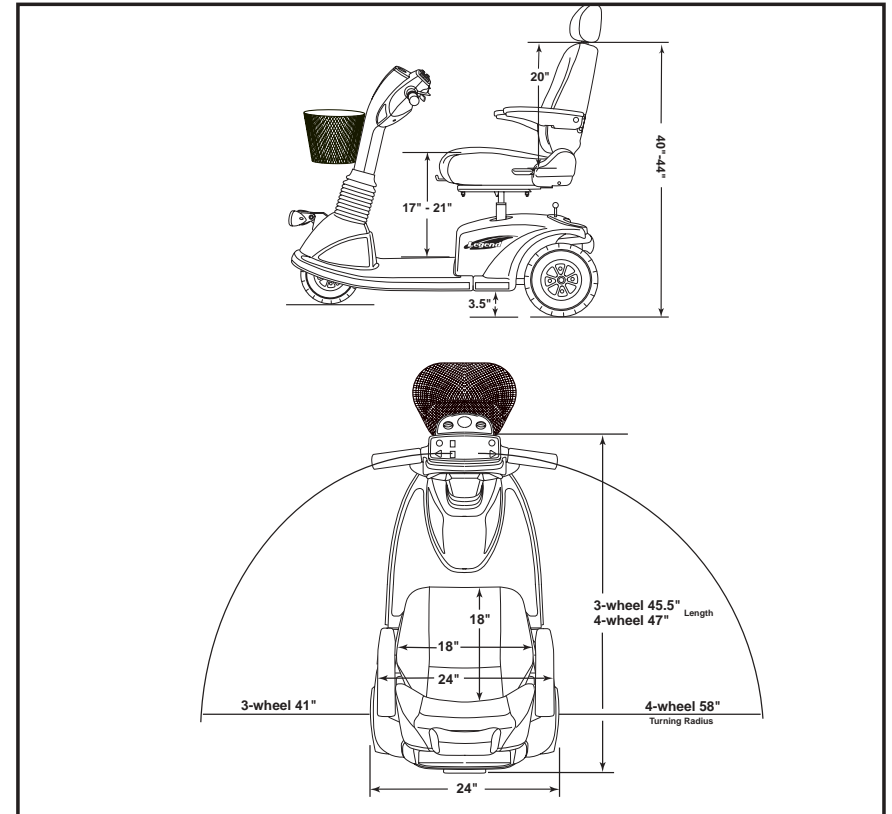

Figure 4. Scooter Dimensions

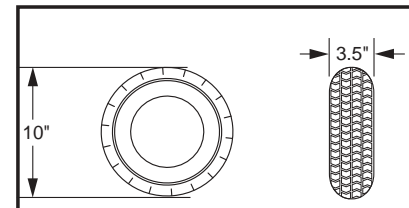

Figure 4A. Front Tire Dimensions

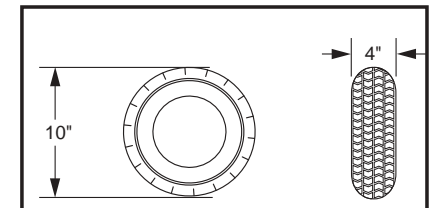

Figure 4B. Rear Tire Dimensions

IV. SPECIFICATIONS

Model Numbers	3-wheel:SC3000, 4-wheel:SC3400
Available Colors ⁴	Painted: Champagne (Standard)
Overall Length ²	3-wheel: 45.5 in., 4-wheel: 47 in.
Overall Width ²	24 in.
Total Weight Without Batteries	3-wheel: 157 lbs., 4-wheel: 166 lbs.
Heaviest Piece When Disassembled	Rear frame: 61 lbs.
Turning Radius ²	3-wheel: 41 in., 4-wheel: 58 in.
Speed (max) ¹	Variable up to 5.75 mph
Range Per Charge ¹	(With 32 Ah batteries) Up to 25 miles
Ground Clearance ²	3.5 in.
Weight Capacity	350 lbs.
Standard Seating	Type: CRS Deluxe Reclining High Back with headrest and sliders. Dimensions: 18 in. width 18 in. depth 20 in. height; with headrest 24 in. – 28 in. Material: Gray vinyl or Gray fabric
Standard Seat Weight	45 lbs.
Drive System	Rear-wheel drive, sealed transaxle with a 24-volt DC motor
Dual Braking System	Electronic, regenerative, and electromechanical
Wheels	Aluminum alloy mags
Tires	Type: pneumatic; front: 3.5 in. x 10 in., rear: 4 in. x 10 in.
Battery Requirements ³	Two 12-volt deep cycle, Size: U-1, 31-36 Ah
Battery Weight	24.5 lbs. each
Battery Charger	Onboard

¹ Varies with user weight, terrain type, battery amp-hour (Ah rating), battery charge, battery condition, and tire condition.

² Due to manufacturing tolerances and continual product improvement, this specification can be subject to a variance of (+ or -) 3 %.

³ AGM or Gel-Cell type required. See VI. "Batteries and Charging."

⁴ Other colors available through special order.

NOTE: All specifications subject to change without notice.

V. YOUR SCOOTER

TILLER CONSOLE

The tiller console houses all of the controls needed to drive your scooter. See figure 5.



WARNING! Do not expose the tiller console to moisture. In the event that the tiller console does become exposed to moisture, do not attempt to operate your scooter until the tiller console has dried thoroughly.

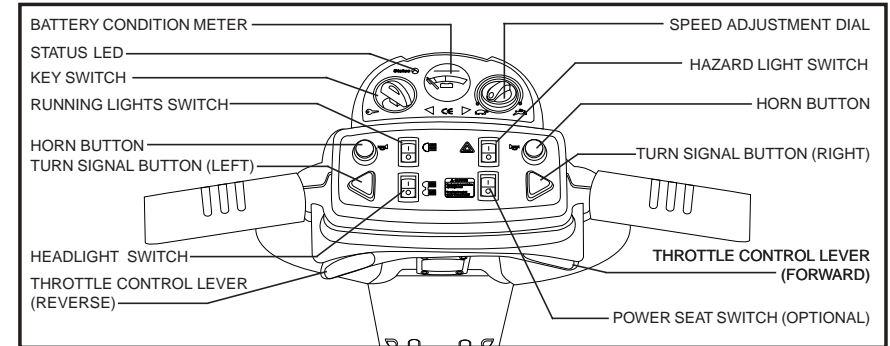

Figure 5. Tiller Console

Key Switch

- Insert the key into the key switch and turn it clockwise to power up (turn on) your scooter.
- Turn the key counterclockwise to power down (turn off) your scooter.



WARNING! If the key is turned to the off position while your scooter is in motion, the electronic brakes engage and your scooter will come to an abrupt stop!

Throttle Control Lever

This lever allows you to control the forward speed and the reverse speed of your scooter up to the maximum speed you preset with the speed adjustment dial.

- Place your right hand on the right handgrip and your left hand on the left handgrip.
- Use your right thumb to push the right side of the lever to disengage your scooter's brakes and move forward.
- Release the lever and allow your scooter to come to a complete stop before pushing the other side of the lever to move in reverse.
- When the throttle is completely released, it automatically returns to the center "stop" position and engages your scooter's brakes.

Speed Adjustment Dial

This dial allows you to preselect and limit your scooter's top speed.

- The image of the tortoise represents the slowest speed setting.
- The image of the hare represents the fastest speed setting.

Status LED

The Status LED alerts you to electrical problems that may occur with the Legend. The LED remains constantly lit while your scooter is on. If the Legend develops an electrical problem, the status LED will flash a code. See XI. "Basic Troubleshooting" for diagnostic flash codes.

V. YOUR SCOOTER

Running Lights Switch

This switch controls your scooter's front (upper) and rear running lights.

- Toggle the switch forward to turn on your scooter's running lights.
- Toggle the switch back to turn off your scooter's running lights.

Headlight Switch

This switch controls your scooter's front (lower) light.

- Toggle the switch forward to turn on your scooter's front lower light.
- Toggle the switch back to turn off the light.

Horn Buttons

These buttons activate a warning horn. Your scooter must be turned on for the horn to be operational. Do not hesitate to use the warning horn when doing so may prevent accident or injury.

Hazard Lights Switch

This switch activates the 4-way flashers on your scooter.

- Toggle the switch forward to turn on the flashers.
- Toggle the switch back to turn off the flashers.

Turn Signal Buttons

- Press the appropriate turn signal button once to activate it.
- Your scooter's turn signals are timed to shut off automatically.

3-Amp Tiller Console Fuses

These fuses help protect your scooter's front lighting, turn signals, and key switch console systems from receiving an overload of electrical current. The fuses used in your scooter are the same type used in automobiles. See XI. "Care and Maintenance" for fuse replacement.

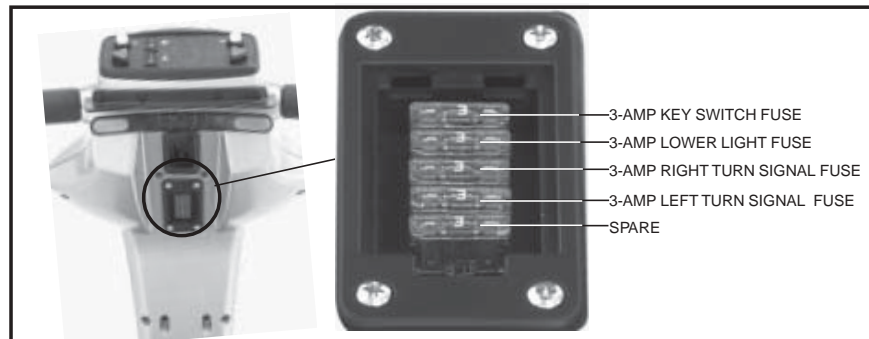

Figure 5A. Tiller Console Fuses

V. YOUR SCOOTER

REAR SECTION

The onboard battery charger (not shown), the charger power cord receptacle, the batteries (not shown), the main circuit breaker reset button, the ammeter, the manual freewheel lever, the anti-tip wheels, and the motor/transaxle assembly are located on the rear section of your scooter. See figure 6.

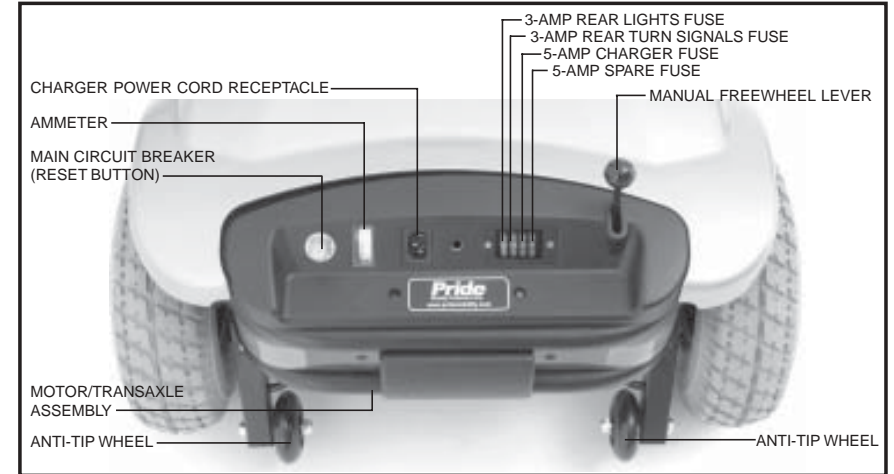

Figure 6. Rear Section

Charger Power Cord Receptacle

The charger power cord plugs into your scooter's battery charger by means of the charger power cord receptacle.

Ammeter

During charging, the ammeter indicates the charging rate, or how hard the charger is working to charge the Legend's batteries. See VI. "Batteries and Charging."

Main Circuit Breaker (Reset Button)

When the voltage in your scooter's batteries becomes low or the scooter is heavily strained because of excessive loads or steep inclines, the main circuit breaker may trip to protect the motor and electronics from damage. See figure 6.

- The main circuit breaker reset button pops out when the breaker trips.
- When the breaker trips, the entire electrical system of your scooter shuts down.
- Allow a minute or two for your scooter's electronics to "rest."
- Push in the reset button to reset the main circuit breaker.
- If the main circuit breaker trips frequently, you may need to charge your batteries more often. You may also need to have your authorized Pride Provider perform a load test on your scooter's batteries.
- If the main circuit breaker trips repeatedly, see your authorized Pride Provider for service.

V. YOUR SCOOTER

Manual Freewheel Lever

Whenever you need or want to push your scooter for short distances, you can put it in freewheel mode.

1. Remove the key from the key switch.
2. Pull up on the manual freewheel lever to disable the drive system and the brake system. You may now push your scooter.
3. Push down on the manual freewheel lever to reengage the drive and the brake systems and take your scooter out of freewheel mode.

WARNING! When your scooter is in freewheel mode, the braking system is disengaged.

- Disengage the drive motors only on a level surface.
- Ensure the key is removed from the key switch.
- Stand to the side of the scooter to engage or disengage freewheel mode. Never sit on a scooter to do this.
- After you have finished pushing your scooter, always return it to the drive mode to lock the brakes.



NOTE: If the scooter is placed in freewheel mode (manual freewheel lever pulled up) while the key is in the on position, the scooter will not run until the manual freewheel lever is pushed down and the key is turned to the “off” position, then back to the “on” position.

Batteries (Not Shown)

The batteries store electrical energy that powers your scooter. See VI. “Batteries and Charging.”

Anti-tip Wheels

The anti-tip wheels are an integral and important safety feature designed to help prevent your scooter from tipping rearwards on an incline. They are bolted to the frame at the rearmost part of your scooter.



PROHIBITED! Do not remove the anti-tip wheels or modify your scooter in any way that is not authorized by Pride.

Motor/Transaxle Assembly

The motor/transaxle assembly is an electromechanical unit that converts electrical energy from your scooter’s batteries into the controlled mechanical energy that drives the Legend’s wheels.

Rear Fuses

These fuses help protect your scooter’s rear lighting, turn signals, and charging systems from receiving an overload of electrical current. These fuses are the same type used in automobiles. See XI. “Care and Maintenance” for fuse replacement.

VI. BATTERIES AND CHARGING

Your scooter requires two long-lasting, 12-volt, deep-cycle batteries that are sealed and maintenance free. They are recharged by an on-board charging system.

- Charge your scooter’s batteries prior to using it for the first time.
- Keep the batteries fully charged to keep your scooter running smoothly.

READING YOUR BATTERY VOLTAGE

The battery condition meter on the tiller console indicates the approximate strength of your batteries using a color code. From right to left, green indicates fully charged batteries, yellow a draining charge, and red indicates that an immediate recharge is necessary. See figure 7. To ensure the highest accuracy, the battery condition meter should be checked while operating your scooter at full speed on a dry, level surface.

You can also check the charging status of the batteries by the ammeter, located at the rear of the scooter. The charger power cord must be plugged into a standard electrical outlet in order to obtain a reading. When the amperage reading is at or near zero amps, charging is complete. See figure 8.

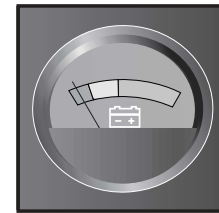

Figure 7. Battery Condition Meter



Figure 8. Ammeter Indicates Battery Is Fully Charged

CHARGING YOUR BATTERIES



PROHIBITED! Removal of grounding prong can create electrical hazard. If necessary, properly install an approved 3-pronged adapter to an electrical outlet having 2-pronged plug access.



PROHIBITED! Never use an extension lead to plug in your battery charger. Plug the charger directly into a properly wired standard electrical outlet.



MANDATORY! Read the battery charging instructions in this manual and in the manual supplied with the battery charger before charging the batteries.



WARNING! Explosive gases may be generated while charging the batteries. Keep the scooter and battery charger away from sources of ignition such as flames or sparks and provide adequate ventilation when charging the batteries.

WARNING! You must recharge your scooter’s batteries with the supplied onboard charger. Do not use an automotive-type battery charger.



WARNING! Inspect the battery charger, wiring and connectors for damage before each use. Contact your authorized Pride Provider if damage is found.

WARNING! Do not attempt to open the battery charger case. If the battery charger does not appear to be working correctly, contact your authorized Pride Provider.

WARNING! If the battery charger is equipped with cooling slots, then do not attempt to insert objects through these slots.

VI. BATTERIES AND CHARGING



PROHIBITED! Do not allow unsupervised children to play near the scooter while the batteries are charging. Pride recommends that you do not charge the batteries while the scooter is occupied.



WARNING! If your battery charger has not been tested and approved for outdoor use, then do not expose it to adverse or extreme weather conditions. If the battery charger is exposed to adverse or extreme weather conditions, then it must be allowed to adjust to the difference in environmental conditions before use indoors. Refer to the manual supplied with the battery charger for more information.



Follow these easy steps to charge your batteries safely:

1. Position your scooter close to a standard electrical outlet.
2. Remove the key from the key switch.
3. Make certain that the manual freewheel lever is in the drive (down) position.
4. Plug the charger power cord into the charger power cord receptacle.
5. Extend the charger power cord and plug it into the electrical outlet. It is recommended that you charge your batteries for 8 to 14 hours.
6. When the batteries are fully charged, unplug the charger power cord from the electrical outlet and then from the charger power cord receptacle.

NOTE: There is a charger inhibit function on your scooter. The scooter will not run and the battery condition meter will not operate while the batteries are charging.

FREQUENTLY ASKED QUESTIONS

How does the charger work?

When your scooter's battery voltage is low, the charger works harder, sending more electrical current to the batteries to bring up their charge. As the batteries approach a full charge, the charger sends less and less electrical current. When the batteries are fully charged, the current sent from the charger is at nearly zero amperage. Therefore, when the charger is plugged in, it maintains the charge on your scooter's batteries, but does not overcharge them. We do not recommend that you charge your scooter's batteries for more than 24 consecutive hours.

What if my scooter's batteries won't charge?

- Ensure the red (+) and black (-) battery cables are connected properly to the battery terminals.
- Ensure both battery harnesses, extending from the batteries, are plugged into their mating harness leading to the charger.
- Ensure both ends of the charger power cord are inserted fully.

Can I use a different charger?

Chargers are selected precisely for particular applications and are especially matched to the type, size, and chemical formulation of specific batteries. For the safest and most efficient charging of your scooter's batteries, we recommend use of the charger supplied as original equipment with your Pride product only. Any charging method resulting in batteries being charged individually is especially prohibited.

VI. BATTERIES AND CHARGING

How often must I charge the batteries?

Two major factors must be considered when deciding how often to charge your scooter's batteries:

- All day scooter use on a daily basis.
- Infrequent or sporadic scooter use.

With these considerations in mind, you can determine how often and for how long you should charge your scooter's batteries. We designed the onboard charger so that it will not overcharge your scooter's batteries. However, you may encounter some problems if you do not charge your batteries often enough and if you do not charge them on a regular basis. Following the guidelines below will provide safe and reliable battery operation and charging.

- If you use your scooter daily, charge its batteries as soon as you finish using it for the day. Your scooter will be ready each morning. We recommend that you charge your scooter's batteries for 8 to 14 hours after daily use.
- If you use your scooter once a week or less, charge its batteries at least once a week for 12 to 14 hours at a time.
- Keep your scooter's batteries fully charged.
- Avoid deeply discharging your scooter's batteries.

How can I ensure maximum battery life?

Fully charged deep-cycle batteries provide reliable performance and extended battery life. Keep your scooter's batteries fully charged whenever possible. Protect your scooter and batteries from extreme heat or cold. Batteries that are regularly and deeply discharged, infrequently charged, stored in extreme temperatures, or stored without a full charge may be permanently damaged, causing unreliable performance and limited service life.

How can I get maximum range or distance per charge?

Rarely will you have ideal driving conditions—smooth, flat, hard driving surfaces with no wind or curves. Often, you will face hills, pavement cracks, uneven and loosely packed surfaces, curves, and wind, all of which affect the distance or running time per battery charge. Below are a few suggestions for obtaining the maximum range per battery charge.

- Always fully charge your scooter's batteries prior to daily use.
- Maintain **30-35 psi** in each tire.
- Plan your route ahead to avoid as many hills, cracked, broken, or soft surfaces as possible.
- Limit your baggage weight to essential items.
- Try to maintain an even speed while your scooter is in motion.
- Avoid stop-and-go driving.

What type and size of battery should I use?

We recommend deep-cycle batteries that are sealed and maintenance free. Both AGM and Gel-Cell are deep-cycle batteries that are similar in performance. Do not use wet-cell batteries, which have removable caps.



WARNING! Corrosive chemicals are contained in batteries. Use only AGM or Gel-Cell batteries to reduce the risk of leakage or explosive conditions.

NOTE: Sealed batteries are not serviceable. Do not remove the caps.

VI. BATTERIES AND CHARGING

How do I change a battery?

WARNING! Contact your authorized Pride Provider if you have any questions regarding the batteries in your scooter.



WARNING! Do not replace the batteries while the scooter is occupied.

WARNING! The batteries on your scooter should only be serviced or replaced by an authorized Pride Provider or a qualified technician.



MANDATORY! Battery posts, terminals and related accessories contain lead and lead compounds. Wear goggles and gloves when handling batteries and wash hands after handling.



WARNING! Always use two batteries of the exact same type, chemistry and amp-hour (Ah) capacity. Refer to the specifications table in this manual and in the manual supplied with the battery charger for recommended type and capacities.

1. Remove the seat and the rear shroud. See IX. "Disassembly and Assembly."
2. Disconnect the battery strap.
3. Disconnect the 2 pin, black and white battery harness from its mating plug. See figure 15 in IX. "Assembly and Disassembly."
4. Disconnect the battery cables from the battery terminals.
5. Remove the old batteries.
6. Place a the new batteries into the battery wells.
7. Connect the red battery cable to the positive (+) battery terminal for each battery.
8. Connect the black battery cable to the negative (-) battery terminal for each battery.
9. Reconnect the 2 pin, black and white battery harness to its mating plugs.
10. Reconnect the battery strap.
11. Reinstall the rear shroud and seat.

NOTE: If you encounter a damaged or cracked battery, immediately enclose it in a plastic bag and call your authorized Pride Provider for instructions on disposal. Your authorized Pride Provider will also have the necessary information on battery recycling, which is our recommended course of action.

Why do my new batteries seem weak?

Deep-cycle batteries employ a different chemical technology than that used in car batteries, nickel-cadmium batteries (nicads), and other common battery types. Deep-cycle batteries are specifically designed to provide power, drain down their charge, and then accept a relatively quick recharge.

We work closely with our battery manufacturer to provide batteries that best suit your scooter's specific electrical demands. Fresh batteries are shipped fully charged to our customers. During shipping, the batteries may encounter temperature extremes that can influence their initial performance. Heat diminishes the charge on the battery; cold slows the available power and extends the time needed to recharge the battery.

VI. BATTERIES AND CHARGING

It may take a few days for the temperature of your scooter's batteries to stabilize and adjust to their new room or ambient temperature.

More importantly, it takes a few charging cycles (partial draining followed by full recharging) to establish the critical chemical balance that is essential to a deep-cycle battery's peak performance and long life.

Follow these steps to properly break in your scooter's new batteries for maximum efficiency and service life.

1. Fully recharge any new battery prior to its initial use. This charging cycle brings the battery up to about 88% of its peak performance level.
2. Operate your new scooter in familiar and safe areas. Drive slowly at first, and do not travel too far from your home or familiar surroundings until you have become accustomed to your scooter's controls and have properly broken in your scooter's batteries.
3. Fully recharge the batteries. They should be at over 90% of their peak performance level.
4. Operate your scooter again.
5. Fully recharge the batteries again.
6. After four or five charging cycles, the batteries are able to receive a charge of 100% of their peak performance level and are able to last for an extended period of time.

What about public transportation?

If you intend to use public transportation with your scooter, you must contact the transportation provider in advance to determine their specific requirements.

VII. OPERATION

BEFORE GETTING ONTO YOUR SCOOTER

- Have you fully charged the batteries? See VI. “Batteries and Charging.”
- Is the manual freewheel lever in the drive (down) position? Never leave the manual freewheel lever pulled up unless you are manually pushing your scooter.

GETTING ONTO YOUR SCOOTER

1. Make certain that the key is removed from the key switch.



WARNING! Never attempt to get onto or off of your scooter without first removing the key from the key switch. This will prevent the scooter from moving if accidental throttle control lever contact is made.

2. Stand at the side of your scooter.
3. Disengage the seat rotation lever and rotate the seat until it is facing you.
4. Make certain that the seat is secured into position.
5. Position yourself comfortably and securely in the seat.
6. Disengage the seat rotation lever and rotate the seat until you are facing forward.
7. Make certain that the seat is secured into position.
8. Make certain that your feet are safely on the floorboard.

PRE-RIDE ADJUSTMENTS AND CHECKS

- Is the seat at the proper height? See VIII. “Comfort Adjustments.”
- Is the seat securely in place?
- Is the tiller at a comfortable setting and secured into place? See VIII. “Comfort Adjustments.”
- Is the key fully inserted into the key switch and turned clockwise to the “on” position?
- Does the scooter’s horn work properly?
- Is your proposed path clear of people, pets, and obstacles?
- Have you planned your route to avoid adverse terrain and as many inclines as possible?

OPERATING YOUR SCOOTER

WARNING! The following can adversely affect steering and stability while operating your scooter:



- Holding onto or attaching a leash to walk your pet
- Carrying passengers (including pets)
- Hanging any article from the tiller
- Towing or being pushed by another motorized vehicle

Such practices could cause loss of control and/or tipping

Keep both hands on the tiller and your feet on the floorboard at all times while operating your scooter. This driving position gives you the most control over your vehicle.

- Set the speed adjustment dial to your desired speed.
- Press your thumb against the appropriate throttle control lever.
- The electromechanical disc park brake automatically disengages and the scooter accelerates smoothly to the speed you preselected with the speed adjustment dial.
- Pull on the left handgrip to steer your scooter to the left.

VII. OPERATION

- Pull on the right handgrip to steer your scooter to the right.
- Move the tiller to the center position to drive straight ahead.
- To stop, slowly release the throttle control lever. The electronic brakes will automatically engage when your scooter comes to a stop.

NOTE: Your scooter’s reverse speed is slower than that of the forward speed you preset with the speed adjustment dial.

GETTING OFF OF YOUR SCOOTER

1. Bring your scooter to a complete stop.
2. Remove the key from the key switch.
3. Disengage the seat rotation lever and rotate the seat until you are facing toward the side of your scooter.
4. Make certain that the seat is secured into position.
5. Carefully and safely get out of the seat and stand to the side of your scooter.
6. You can leave the seat facing to the side to facilitate boarding your scooter next time.

POWER DOWN TIMER FEATURE

Your scooter is equipped with an energy saving automatic power down timer feature designed to preserve your scooter’s battery life. If you mistakenly leave the key in the key switch and in the “on” position but do not use your scooter for approximately 20 minutes, the scooter’s controller shuts down automatically. Although the controller is shut down, power will still be supplied to the scooter’s lighting system.

If the power down timer feature takes effect, perform the following steps to resume normal operation.

1. Remove the key from the key switch.
2. Reinsert the key and power up your scooter.

VIII. COMFORT ADJUSTMENTS



WARNING! Remove the key from the key switch before adjusting the tiller or the seat. Never attempt to adjust the tiller or the seat while the scooter is in motion.

TILLER ANGLE ADJUSTMENT

Your scooter is equipped with a pivoting tiller that allows adjustment to several positions from the scooter deck to the farthest forward stop.

1. Lift the tiller adjustment lever. See figure 9.
2. Move the tiller to a comfortable position.
3. Release the tiller adjustment lever to secure the tiller in position.



Figure 9. Tiller Adjustment

SEAT ROTATION ADJUSTMENT

The seat rotation lever secures the seat in one of eight positions. See figure 10.

1. Push forward on the seat rotation lever to disengage the seat.
2. Rotate the seat to the desired position.
3. Release the seat rotation lever to secure the seat into place. If the seat is not secured into position, gently rock the seat back and forth until you hear the lever “click.”

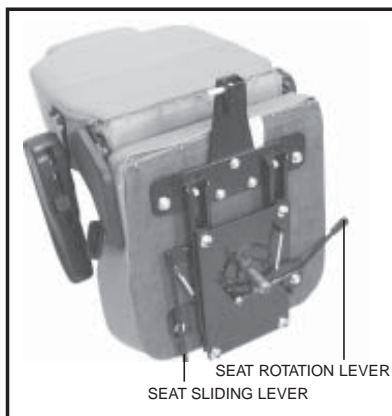

Figure 10. Seat Adjustments

FRONT-TO-BACK SEAT ADJUSTMENT

You can reposition the Legend’s seat forward or rearward to adjust the distance between the seat and the tiller. See figure 10.

1. Move the seat sliding lever outward.
2. While holding the lever out, slide the seat forward or rearward.
3. Release the seat sliding lever once the seat is in the desired position.

VIII. COMFORT ADJUSTMENTS

SEATBACK ADJUSTMENT



WARNING! Do not operate your scooter with the seatback in a reclined position.

WARNING! Always keep your back pressed firmly against the seat back while adjusting it.

To adjust your scooter’s reclining seat, perform these steps. See figure 10A.

1. While pulling up on the seatback adjustment lever, lean forward or backward to adjust the seatback.
2. Release the seatback adjustment lever once the seat is in a comfortable riding position.

ARMREST ANGLE ADJUSTMENT

The armrests of your scooter can be adjusted upward or downward by using the adjustment dial. See figure 10B. By turning the adjustment dial, the armrest will either raise or lower.

NOTE: The armrests pivot upward to make getting on and off of your scooter easier.



Figure 10A. Seatback Adjustment Lever

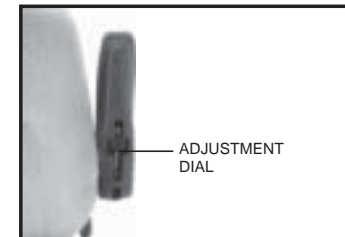

Figure 10B. Armrest Angle Adjustment

SEAT HEIGHT ADJUSTMENT

The seat can be repositioned to different heights. See figure 11.

1. Remove the seat and shroud from your Scooter. See IX. “Disassembly and Assembly.”
2. Loosen the seat height adjustment bolt-nut and remove it from the bolt. Remove the bolt and washers.
3. Loosen the seat post bolt.
4. Raise or lower the upper seat post to the desired seat height.
5. While holding the upper seat post at that height, match up the locating holes in the upper seat post with those of the lower seat post.
6. With one washer on the seat height adjustment bolt insert it through the locating holes of both the upper and lower seat posts. Reinstall the other washer and bolt-nut and tighten.

NOTE: Ensure both washers have been reinstalled before fully tightening the bolt-nut.

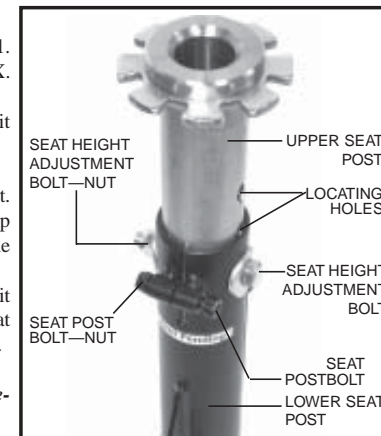

Figure 11. Seat Height Adjustment

7. Tighten the seat post bolt.
8. Reinstall the rear shroud and the seat.

VIII. COMFORT ADJUSTMENTS

POWER SEAT (OPTIONAL)

Your scooter may be equipped with a power seat option, a power seat switch will be located on the tiller console. See figure 5. The power seat will be equipped with one of two operating systems. Refer to figures 12 and 13 to determine which system your scooter uses and follow the appropriate instructions for safe operation.



WARNING! The power seat is intended for operation only while your scooter is stationary and on a level surface. Its purpose is to aid you in reaching objects. Drive your scooter only with the power seat in the lowest position. Driving the scooter with power seat elevated could result in personal injury, equipment and/or property damage.

Strict adherence to the following safety rules is vital to your safety:

- Operate the power seat only while completely stationary on level ground.
- Do not press the throttle control lever and the power seat switch at the same time.
- Do not operate your scooter with the power seat elevated. Operate the scooter only with the power seat fully retracted (in the lowest position).
- Never place your scooter in freewheel mode with the power seat elevated.
- Use extreme caution when reaching for objects with your power seat elevated. Do not overextend or attempt to pick up objects that might affect your balance.
- Do not attempt to raise or lower the seat while in motion.

Before operating the power seat, ensure your scooter is level and stationary and the speed adjustment dial is set to the slowest setting.

System 1 - Operation using power seat switch and throttle control lever:

1. Release the throttle control lever.
2. Toggle the power seat switch located on the tiller console to the “on” position. See figure 12.
3. To raise the power seat, operate your throttle control lever in the forward direction.
4. Release the throttle control lever when you have attained your desired height.
5. To lower the power seat, operate your throttle control lever in the reverse direction.
6. Ensure your seat is in the lowest position and that you have fully released the throttle control lever.
7. Toggle “off” the power seat switch before you attempt to drive your scooter again.

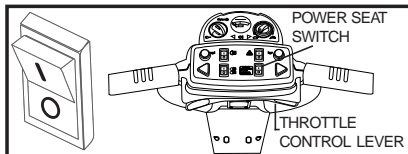

Figure 12. Power Seat Switch (With Vertical Line And Circle) Used In Conjunction With Throttle Control Lever to Activate The Power Seat Actuator (Switch Shown In The “Off” Position)

System 2 - Operation with power seat switch only:

1. To raise the power seat, press and hold the upper part of the switch. Release the switch when you have attained your desired height or upon reaching the highest position. See figure 13.
2. To lower the power seat, press and hold the lower part of the switch. Release the switch when you have attained your desired height or upon reaching the lowest position.

NOTE: The scooter must be stopped in order for the power seat to be operated. If the power seat switch is pressed while the scooter is in motion, the scooter will slow and come to a stop. The scooter may also produce a fault code indicated by the Status LED on the console. If a fault code occurs, you will need to turn the scooter’s power off then back on again before proceeding.

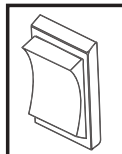

Figure 13. Power Seat Switch (With No Markings)-Activates The Power Seat Actuator

IX. DISASSEMBLY AND ASSEMBLY

DISASSEMBLY

You can disassemble the scooter into seven pieces: the seat, the front section, the rear section, the rear shroud, the basket, and the batteries. See figure 14. No tools are required to disassemble or assemble your scooter, but keep in mind that the disassembled sections of the scooter take up more floor space than the assembled unit. Always disassemble or assemble your scooter on a level, dry surface with sufficient room for you to work and move around your scooter—about 5 feet in all directions. Remember that some scooter components are heavy and you may need assistance when lifting them.



WARNING! Lifting weight beyond your physical capability may result in personal injury. Ask for assistance when necessary while disassembling or assembling your scooter.



Figure 14. The Legend Disassembled

1. Place the manual freewheel lever in the drive (down) position.
2. Coil the charger power cord and store it for future use.
3. Push forward on the seat rotation lever to rotate the seat; lift the seat up and off the scooter. See figure 15.
4. Gently pull the shroud away from the frame at the bottom and lift it off of the scooter. See figure 16.
5. Disconnect the battery strap.



Figure 15. Removing The Seat



Figure 16. Rear Shroud Removal

IX. DISASSEMBLY AND ASSEMBLY

- Unplug both black and white 2-pin battery harnesses. See figure 17.
- Unplug the front-to-rear harness. See figure 18.



WARNING! Failure to unplug both battery harnesses and the front-to-rear harness prior to separating the front and rear sections could result in permanent damage to the scooter.



Figure 17. Battery Harnesses

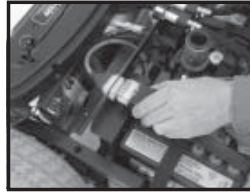

Figure 18. Front-To-Rear Harness

Toggle Latch Release

- Push in the toggle latch release button while pulling back the toggle latch. See figure 19.
- Position the toggle latch buckle over the top of the toggle latch. See figure 20.
- Lower the tiller to the scooter floorboard.



Figure 19. Toggle Latch (Latched)



Figure 20. Toggle Latch (Unlatched)

Frame Separation

- Push back on the seat post to pivot the scooter's rear section backwards until the rear section is standing vertically on its rear bumper. See figure 21.
- Lift the front section up until the lower pegs are no longer in the slots. See figure 22.
- Carefully move the front section away from the rear section.

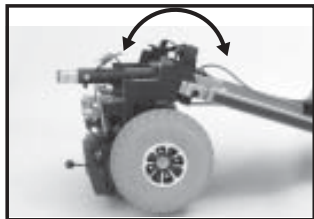

Figure 21. Frame Positioning



Figure 22. Separating The Frame Sections

IX. DISASSEMBLY AND ASSEMBLY

ASSEMBLY

- Position the front and rear sections of your scooter as shown in figure 23.
- Align the lower slots of the front section with the corresponding pegs on the front of the rear section.



WARNING! Position the front-to-rear harness cable so it won't become pinched between the frame halves when pivoting the rear section forward. See figure 24.

- Holding the seat post, slowly pivot the rear section forward until the curved locking brackets are fully connected onto the top rear pegs. See figure 24.
- Raise the tiller.
- Secure the toggle latch. See figure 19.
 - Lower the toggle latch buckle.
 - Push back on the toggle latch so it locks into place.
- Connect the front-to-rear harness and both battery harnesses.
- Replace the shroud.
- Replace the seat and secure it into place.



Figure 23. Frame Sections



Figure 24. Frame Lockup

X. BASIC TROUBLESHOOTING

Any electromechanical device occasionally requires some troubleshooting. However, most of the problems that may arise can usually be solved with a bit of thought and common sense. Many of these problems occur because the batteries are not fully charged or because the batteries are worn down and can no longer hold a charge.

DIAGNOSTIC FLASH CODES

The diagnostic flash codes for your scooter are designed to help you perform basic troubleshooting quickly and easily. A diagnostic flash code will flash from the status LED in the event one of the conditions listed below develops.

NOTE: Your scooter will not run unless the flash code condition is resolved and the scooter has been turned off, then turned back on.

FLASH CODE	CONDITION	SOLUTION
■ ■ (2)	Battery voltage is too low to operate the scooter.	Charge fully until charger and any meters indicate completion.
■ ■ ■ (3)	Battery voltage is too high to operate the scooter.	Call for assistance.
■ ■ ■ ■ ■ (5)	Solenoid brake trip. The manual freewheel lever may be in the freewheel position.	Remove the key, then push the manual freewheel lever to the drive position, restart your scooter.
■ ■ ■ ■ ■ ■ (6)	Throttle trip. The throttle control lever may have been depressed while inserting the key.	Release the throttle control lever completely, then reinsert the key.
■ ■ ■ ■ ■ ■ ■ (7)	Throttle trip. Throttle potentiometer fault or speed potentiometer fault.	Call for assistance.
■ ■ ■ ■ ■ ■ ■ ■ (8)	The scooter's motor is disconnected.	Call for assistance.
■ ■ ■ ■ ■ ■ ■ ■ ■ (9)	Possible controller trip. You may be attempting to install the battery packs while the key is inserted or the motor controller may be in overheat protective mode.	Shut down your scooter for a minimum of several minutes to allow the controller to cool. Or, try turning your scooter off, then back on.

What if all the systems on my scooter seem to be “dead”?

- Make certain that the key is in the “on” position.
- Check that the batteries are fully charged. See VI. “Batteries and Charging.”
- Push in the main circuit breaker reset button. See V. “Your Scooter.”
- Make certain that both battery harnesses are firmly connected to the rear electronics module and to the battery terminals. See IX. “Disassembly and Assembly.”
- Make sure that the front-to-rear harness is firmly connected to the rear electronics module. See IX. “Disassembly and Assembly.”
- Check the 3-amp fuse located on the lower portion of the tiller console. See XI. “Care and Maintenance” for fuse replacement.
- Be sure the power down timer feature has not been activated.

X. BASIC TROUBLESHOOTING

What if my scooter does not move when I press the throttle control lever?

- When the manual freewheel lever is pulled up, the brakes are disengaged and all power to the motor/transaxle assembly is cut.
- Push down on the manual freewheel lever, turn the scooter off, and then turn the scooter on to return to normal scooter operation.

What if the main circuit breaker repeatedly trips? See V. “Your Scooter.”

- Charge the scooter's batteries more frequently. See VI. “Batteries and Charging.”
- If the problem continues, have both of your scooter's batteries load tested by your authorized Pride Provider.
- You may also perform the load test yourself. Battery load testers are available at most automotive parts stores.
- Follow the directions supplied with the load tester.
- See VI. “Batteries and Charging” or IV. “Specifications” for information about your scooter's battery type.

What if the battery condition meter dips way down and the motor surges or hesitates when I press the throttle control lever? (See V. “Your Scooter.”)

- Fully charge your scooter's batteries. See VI. “Batteries and Charging.”
- Have your authorized Pride Provider load test each battery.
- Or, see the previous troubleshooting question for load testing the batteries yourself.

If you experience any problems with your scooter that you are not able to solve, immediately contact your authorized Pride Provider for information, maintenance, and service.

XI. CARE AND MAINTENANCE

Your scooter requires a minimal amount of care and maintenance. If you do not feel confident in your ability to perform the maintenance listed below, you may schedule inspection and maintenance at your authorized Pride Provider. The following areas require periodic inspection and/or care and maintenance.

TIRE PRESSURE

- If equipped with pneumatic tires, always maintain a proper **30-35 psi** tire pressure.



WARNING! It is important that 30-35 psi tire pressure be maintained in pneumatic tires at all times. Do not underinflate or overinflate your tires. Low pressure may result in loss of control, and overinflated tires may burst. Failure to maintain 30-35 psi tire pressure in pneumatic tires at all times may result in tire and/or wheel failure.

- Regularly inspect your scooter's tires for signs of wear.

WHEEL REPLACEMENT

If your scooter is equipped with pneumatic tires and you have a flat tire, you can have the tube replaced. If your scooter is equipped with a solid tire insert, either the solid insert or the entire wheel must be replaced depending on model. Contact your authorized Pride Provider for information regarding replacement wheels for your scooter.

WARNING! Wheels on your scooter should only be serviced/replaced by an authorized Pride Provider or qualified technician.



WARNING! Completely deflate pneumatic tires before dismantling the rim or attempting repair.

WARNING! When changing a tire, remove only the center lug nut, then remove the wheel. If any further disassembly is required, deflate the tire completely or it may explode.

EXTERIOR SURFACES

Bumpers, tires, trim, and the tiller boot can benefit from an occasional application of a rubber or vinyl conditioner.



WARNING! Do not use a rubber or vinyl conditioner on the scooter's vinyl seat or tire tread, as they will become dangerously slippery.

CLEANING AND DISINFECTION

- Use a damp cloth and mild, non-abrasive cleanser to clean the plastic and metal parts of your scooter. Avoid using products that may scratch the surface of your scooter.
- If necessary, clean your product with an approved disinfectant. Make sure the disinfectant is safe for use on your product before application.



WARNING! Follow all safety instructions for the proper use of the disinfectant and/or cleaning agent before applying it to your product. Failure to comply may result in skin irritation or premature deterioration of upholstery and/or scooter finishes.

BATTERY TERMINAL CONNECTIONS

- Make certain that the terminal connections remain tight and uncorroded.
- The batteries must sit flat in the battery wells.
- The battery terminals should face the rear of the scooter.

XI. CARE AND MAINTENANCE

WIRING HARNESSSES

- Regularly check all wiring connections.
- Regularly check all wiring insulation, including the charger power cord, for wear or damage.
- Have your authorized Pride Provider repair or replace any damaged connector, connection, or insulation that you find before using your scooter again.



WARNING! Even though the scooter has passed the necessary testing requirements for ingress of liquids, you should keep electrical connections away from sources of dampness, including direct exposure to water or bodily fluids and incontinence. Check electrical components frequently for signs of corrosion and replace as necessary.

ABS PLASTIC SHROUDS

- The front tiller shroud, front shroud, and the rear shroud are formed from durable ABS plastic and are coated with an advanced formula urethane paint.
- A light application of car wax will help the shrouds retain their high gloss.

AXLE BEARINGS AND THE MOTOR/TRANSAXLE ASSEMBLY

These items are all prelubricated, sealed, and require no subsequent lubrication.

MOTOR BRUSHES

The motor brushes are housed inside of the motor transaxle/assembly. They should be inspected periodically for wear by your authorized Pride Provider.

CONSOLE, CHARGER, AND REAR ELECTRONICS

- Keep these areas free of moisture.
- Allow these areas to dry thoroughly if they have been exposed to moisture before charging the batteries and operating your scooter again.

FUSE REPLACEMENT



WARNING! The replacement fuse must exactly match the rating of the old fuse. Failure to use properly rated fuses may cause damage to the electrical system.

In the event a fuse should cease to work:

1. Remove the fuse by pulling it out of its slot.
2. Examine the fuse to be sure it is blown. See figures 25 and 25A.
3. Insert a new fuse of the proper rating.

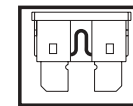

Figure 25. Working Fuse

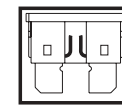

Figure 25A. Blown Fuse (Replace)

XI. CARE AND MAINTENANCE

LIGHT BULB REPLACEMENT

The scooter's light bulbs are easily replaceable. Do not use regular automotive-type 12-volt light bulbs; your scooter is equipped with a 24-volt electrical system. Replacement light bulbs can be purchased from your authorized Pride Provider.

NOTE: Use only 24-volt light bulbs.

1. Remove the light cover.
2. Gently remove the bulb by pulling it straight out.
3. Insert a new bulb of the same wattage.
4. Replace the light cover.

NYLON LOCK NUT REPLACEMENT

Any nylon insert lock nut removed during the periodic maintenance, assembly or disassembly of the scooter must be replaced with a new nut. Nylon insert lock nuts should not be reused as it may cause damage to the nylon insert, resulting in a less secure fit. Replacement nylon insert lock nuts are available at local hardware stores or through your authorized Pride Provider.

STORING YOUR SCOOTER

If you plan on not using your scooter for an extended period of time, it is best to:

1. Fully charge its batteries prior to storage.
2. Disconnect the batteries from the scooter.
3. Store your scooter in a warm, dry environment.
4. Avoid storing your scooter where it will be exposed to temperature extremes.



WARNING! Always protect batteries from freezing temperatures and never charge a frozen battery. Charging a frozen battery may result in damage to the battery.

Batteries that are regularly and deeply discharged, infrequently charged, stored in extreme temperatures, or stored without a full charge may be permanently damaged, causing unreliable performance and limited service life. It is recommended that you charge the scooter batteries periodically throughout periods of prolonged storage to ensure proper performance.

You may wish to place several boards under the frame of your scooter to raise it off of the ground during periods of prolonged storage. This takes the weight off the tires and reduces the possibility of flat spots developing on the areas of the tires contacting the ground.

DISPOSAL OF YOUR SCOOTER

Your scooter must be disposed of according to applicable local and national statutory regulations. Contact your local waste disposal agency or authorized Pride Provider for information on proper disposal of packaging, metal frame components, plastic components, electronics, and batteries.

XII. WARRANTY

THREE-YEAR LIMITED WARRANTY

For three (3) years from the date of purchase, Pride will repair or replace at our option to the original purchaser, free of charge, any of the following parts found upon examination by an authorized representative of Pride to be defective in material and/or workmanship:

Structural Frame Components, Including:

- Main Frame
- Fork
- Seat Post
- Tiller Frame

THREE-YEAR PRORATA WARRANTY

Three-year prorata drivetrain warranty, including:

- Transaxle
- Motor Brake (electronic function ONLY)
- Brake

These components will be prorated on the following schedule:

- First year: 100% replacement of parts cost
- Second year: 67% replacement of parts cost
- Third year: 50% replacement of parts cost

NOTE: If there is an increase in the operational noise level in the transaxle, the warranty does not apply. An increase in operational noise level usually occurs due to abusive and excessive strain on the scooter.

ONE-YEAR LIMITED WARRANTY

For one (1) year from the date of purchase, Pride will repair or replace at our option to the original purchaser, free of charge, any of the following parts found upon examination by an authorized representative of Pride to be defective in material and/or workmanship:

- Bearings
- Bushings
- Rubber Components
- Plastic components except body

Also, electronic assemblies including:

- Electronic Controllers
- Chargers
- Harnesses
- Any other electrical subassembly

SIX-MONTH WARRANTY

The battery is covered by a separate six-month warranty, provided by the battery manufacturer. The batteries are not warranted by Pride.

RECONDITIONED UNITS WARRANTY

All reconditioned units are covered by a six-month warranty from Pride effective from the date of purchase.

WARRANTY EXCLUSIONS

This warranty does not extend to those items which may require replacement due to normal wear and tear.

- ABS Plastic shrouds
- Motor brushes
- Upholstery and seating
- Brake Pads
- Tires and tubes
- Fuses/Bulbs

NOTES



Pride

Mobility Products Corp.

***182 Susquehanna Ave.
Exeter, PA 18643***

1-800-800-8586

www.pridemobility.com

*** I NFMANU2020 ***